

Cameron Rollerball and Fountain Pen Kits

Kit Features:

- Classic, Clean Design
- Combination Thread/Friction Fit Cap
- Easy to Turn With Straight Tubes
- Minimal Parts - easy to assemble
- Available in multiple finishes
- Overall Length: 5-5/16"
- USES REFILL: #PK10-RPR

Required Accessories:

- 7mm Pen Mandrel
- Drill Bit: PK-125MMSG & #PK-105MMSG for plastic and #PKPLI-DB & #PK105MM for wood
- Bushing Set(3pc): #PKCMRBU
- Barrel Trimming set: #PKMAJJRBTS or 10.5mm and 12.5mm sleeves from PKTRIMSET.
- Live Tailstock or Mandrel Saver
- 2 part Epoxy or Thick CA (Cyanoacrylate) Glue
- Pen Blank Minimum Size: 4-3/16"



DIAGRAM A / PARTS LAYOUT

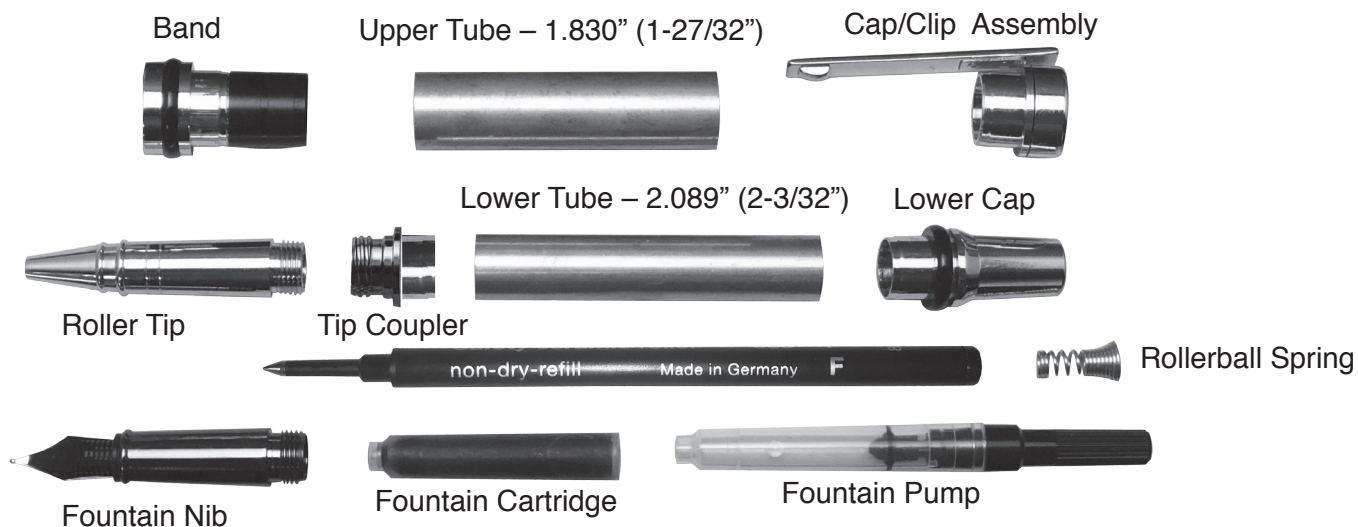

Preparing the Blank:

- Cut blank to the length of the tubes, adding 1/16" for squaring off.
- Drill 12.5mm lengthwise through the short blank and 10.5mm lengthwise through the long blank.
- Spread glue over tube, insert the tube into the blank with a twisting motion to spread the glue evenly inside.
- Center the tube lengthwise inside the blank.
- When the glue is dry, square the ends of the blanks, making sure the trimmed ends are 90° to the tube. Use a barrel trimmer, or a pen blank squaring jig with a sleeve on a disc sander. Take the excess material down flush to the ends of the tubes. Do not trim past the end of the tube since this may interfere with the operation of the mechanism and assembly. Use a barrel trimmer to clean the inside of the tube.

DIAGRAM B / TURNING THE BLANKS

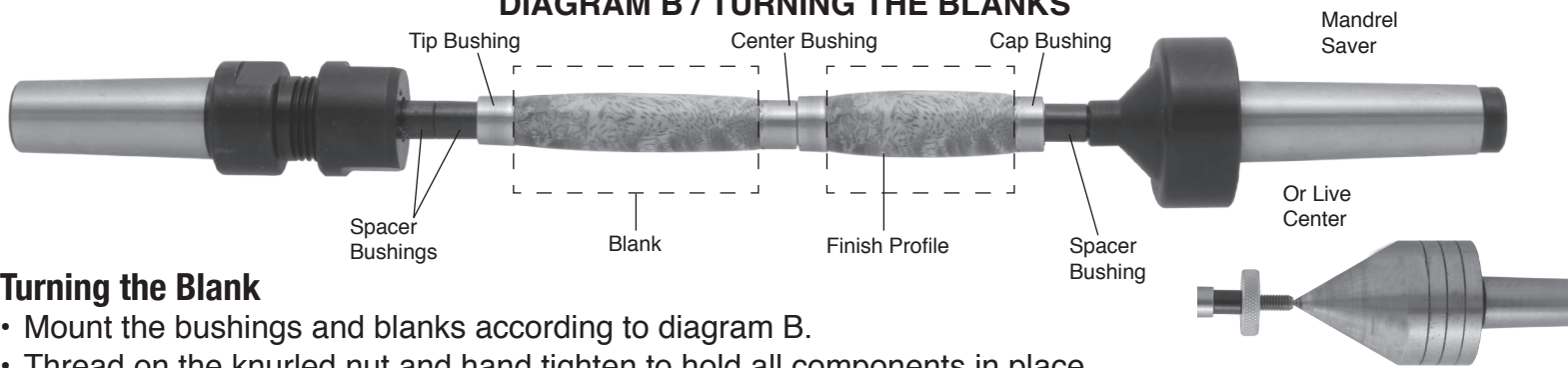
**Turning the Blank**

- Mount the bushings and blanks according to diagram B.
- Thread on the knurled nut and hand tighten to hold all components in place.
- Slide the Tailstock up snugly against the Mandrel shaft, inserting the live center point into the Mandrel dimple. Lock Tailstock.
- Hand tighten the quill adjustment on the tailstock to steady the mandrel. Do not over tighten, it could damage the mandrel shaft.
- When using Mandrel Saver, there is no need for extra spacer bushings or the knurled nut. Slide tailstock directly against bushings and tighten until blank and bushings are secure.
- Using sharp tools, turn the blank down close to the bushing diameter. Turn the barrel straight or to a profile of your choice.
- Sand the blank down to be flush with the bushings, gradually increasing sandpaper grits.
- Finish the barrel using your choice of polish. Allow Sufficient time for the polish to cure—refer to polish instructions.

Assembly

- Lay out parts according to Diagram A
- Press Cap/Clip Assembly into Upper Barrel
- Press Band into opposite end of Upper Barrel
- Press Lower Cap into smaller end of Lower Barrel
- Press Tip Coupler into larger end of Lower Barrel
- For Rollerball pens: drop the Spring into the open end of the lower barrel, followed by the refill-flat side first. Thread the Roller Tip over the refill.
- For Fountain pens: Thread Nib into open Coupler. For ink, you can choose the pre-filled cartridge or refillable pump, either one can be inserted into the back of the Nib Assembly. Note: do not insert pre-filled ink until ready to begin using pen. Ink can dry up and clog nib if left unused in pen for long periods. To use pump, twist back end until plunger is all the way forward. Dip tip into inkwell, and twist back of pump to draw ink into pump. Install nib into Coupler and pen is ready to use.
- Keep cap over pen tip when not in use. Store fountain pen with the nib side up.
- Cap can be pushed onto Lower Cap for safekeeping when pen is in use.

Diagram C / Bushings #PKCMRBU