

# Instructions

## Classic American Rollerball Pen Kit

### Tools Required

- Pen Mandrel
- Mandrel Saver Tailstock Live Centre (Optional)
- Classic American Bushing Set
- 9.7mm Drill Bit
- Pen Assembly Press (Optional)

### Cutting and drilling the blanks

1. Cut each blank 5mm longer than the brass tube.
2. Drill a hole through the centre of the blank.  
Either use a drill press with the blank secured in a vice or clamp or use your lathe with a drill bit mounted into the tailstock chuck.  
Drill at high speed penetrating about 10 mm to 20mm at a time and then clearing the swarf to prevent overheating of the drill bit.  
To prevent cracking or chipping of the wood when the drill bit exits the other end of the blank, stop drilling 3mm before the drill bit reaches the end of the blank and then trim the end of the blank using a saw to expose the hole.

### Glue the brass tubes into the blanks

1. Using 200 grit sandpaper, lightly scuff the exterior of the brass tubes to prepare them for gluing.
2. Apply a thin layer of superglue or epoxy to the tube and insert the tube into the blank. Rotate the tube as you push it into the blank to spread the glue evenly – this must be done fairly quickly to avoid getting the barrel stuck before it's inside the blank.
3. Position the tube inside the blank so that the wood extends beyond the tube on both ends to allow for trimming.

### Trimming the blanks

Square the ends of the wood blank with the tube using a disc sander.

Alternatively, fasten the blank into the spindle chuck on the lathe and trim the barrel carefully using a parting tool.

### Mandrel setup and turning

1. Assemble the bushings and the blanks onto the mandrel as shown in the diagram below.
2. Ensure that the mandrel is tight on your lathe using the mandrel saver tailstock live centre or your live centre in the dimpled end of the mandrel. Do not over-tighten the tailstock or mandrel nut as this may cause the mandrel to flex resulting in off-centre barrels.
3. An alternative is to use a mandrel saver tool to tighten the blank into the lathe without putting strain on the mandrel shaft.
4. Turn the blanks to the desired shape leaving the blanks slightly larger than the bushings.
5. After turning, sand the blanks using progressively finer sandpaper until the desired finish is reached.

# Mr Woodturner

PEN KITS & ACCESSORIES

www.mrwoodturner.co.za

### Turning the tenon

1. A tenon must be cut in the cap to accommodate the centre band.
2. Use a pencil to mark the tenon 3mm from the upper barrel on the centre bushing end.
3. Use a parting tool to cut the tenon down to the brass tube.
4. Ensure that the cut is straight so that a sharp 90° corner is obtained.

### General assembly points

Use a pen assembly press or vice/clamp with wood/plastic jaws to prevent damage to the parts during assembly.

### Pen assembly

Layout the parts as shown below.

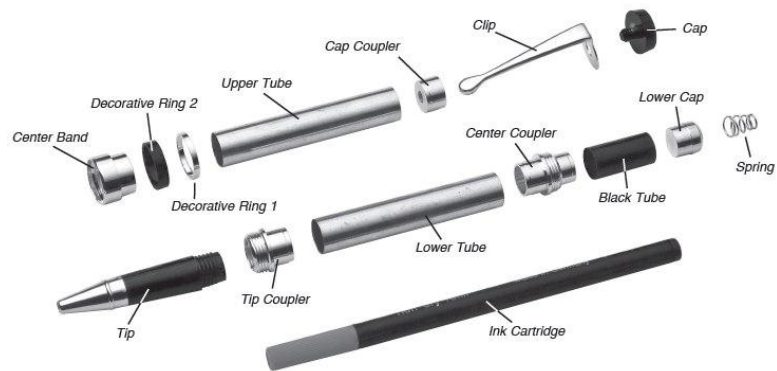

1. Slide the decorative rings onto the centre band as shown in the diagram above and press the assembly onto the exposed brass of the upper tube. If loose, carefully glue into place with a small amount of CA (cyanoacrylate) glue.
2. Unscrew the cap coupler from the cap and press it into the other end of the upper tube.
3. Insert the threaded stud of the cap through the clip and thread the assembly into the cap coupler.
4. Press the tip coupler into the lower tube. Make sure you choose the appropriate end of the tube to preserve the pattern or grain match for your pen.
5. Press centre coupler into open end of lower tube.
6. Press the black tube onto the centre coupler.
7. Gently press the lower cap into the open end of the black tube. Do not press the lower cap in too hard, or it will spread out the black tube and ruin the fit.
8. Insert the spring, large end first, into the tip coupler. Insert the ink cartridge, then thread the tip into the tip coupler.

### Operating the pen

1. Always keep the cap on when not in use to prevent the ink from drying.
2. When using the pen, screw the cap over the body end.

